

MYTORQ

ANLIDAR INDUSTRIAL CO.,LTD.



**BUILT FOR
PRODUCTION LINE**

CORDLESS ASSEMBLY TOOL

my tool , my solution , MYTORQ



Page	Series	Model	Impact Rated R.P.M	Torque (N.m)	Bolt Size (Class 12.9) & Torque	Applicable Battery	Applicable Charge
3	MYBT-IM+ Smart Impact Series	MYBT-IM200+	0~1700	25~180 (Max 200)	(M12) 15 - 110 N.m (M14) 22 - 120 N.m (M16) 22 - 140 N.m (M20) 23 - 200 N.m	SKC-LB1430	MYCS-ID70+
		MYBT-IM100+	0~2000	20~100	(M10) 8 - 40 N.m (M12) 20 - 70 N.m (M14) 20 - 90 N.m (M16) 25 - 100 N.m	SKC-LB1430	MYCS-ID70+
		MYBT-IM70+	0~2600	20~70	(M8) 8 - 30 N.m (M10) 8 - 40 N.m (M12) 20 - 60 N.m (M14) 25 - 70 N.m	SKC-LB1430	MYCS-ID70+
		MYBT-IM50+	0~1900	8~50	(M6) 3 - 20 N.m (M8) 3 - 20 N.m (M10) 5 - 30 N.m (M12) 12 - 50 N.m	SKC-LB1430	MYCS-ID70+

Page	Series	Model	Torque(N.m)		Free Speed (r.p.m)±10%	Applicable Battery	Applicable Charger
			Hard Joint	Soft Joint			
4	MYBT-EP Error Proof Series	MYBT-EP0612	6~12	6~9.6	260~880	SKC-LB1820B	MYCS-ID80-D
		MYBT-EP0309	3~9	3~7.2	300~1000	SKC-LB1820B	MYCS-ID80-D
		MYBT-EP0205F	2~5	2~4	660~2200	SKC-LB1820B	MYCS-ID80-D
5	MYBT-HD Brushless Low Torque	MYBT-HD0320F	0.5~2.0	0.5~1.6	HI : 2700 LO : 1900	SKC-LB1030S	MYCS-ID50
		MYBT-HD0830	0.8~3.0	0.8~2.4	HI : 1400 LO : 1000	SKC-LB1030S	MYCS-ID50
		MYBT-HD1545	1.5~4.5	1.5~3.6	HI : 800 LO : 550	SKC-LB1030S	MYCS-ID50
		MYBT-HD0206	2.0~6.0	2.0~4.8	HI : 650 LO : 450	SKC-LB1030S	MYCS-ID50
6	MYBT-AE Torque Adjustment External Series	MYBT-AE0612	6~12	6~9.6	HI : 880 LO : 570	SKC-LB1820B	MYCS-ID80-D
		MYBT-AE0309	3~9	3~7.2	HI : 1000 LO : 650	SKC-LB1820B	MYCS-ID80-D
		MYBT-AE0205F	2~5	2~4	HI : 2200 -	SKC-LB1820B	MYCS-ID80-D
		MYBT-AE0206	2~6	2~4.8	HI : 1000 LO : 650	SKC-LB1820B	MYCS-ID80-D
		MYBT-AE0135	1~3.5	1~2.8	HI : 1000 LO : 650	SKC-LB1820B	MYCS-ID80-D
		MYBT-AE0135F	1~3.5	1~2.8	HI : 2000 -	SKC-LB1820B	MYCS-ID80-D
7	MYBT-AI Torque Adjustment Internal Series	MYBT-AI0822	8~22	8~17.6	HI : 350 LO : 200	SKC-LB1840	MYCS-ID120 MYCS-ID80 MYCS-80
		MYBT-AI0615	6~15	6~12	HI : 600 LO : 380	SKC-LB1840	MYCS-ID120 MYCS-ID80 MYCS-80
		MYBT-AI0512	5~12	5~9.6	HI : 720 LO : 450	SKC-LB1820 SKC-LB1840	MYCS-ID120 MYCS-ID80 MYCS-80
		MYBT-AI0408	4~8	4~6.4	HI : 1200 LO : 780	SKC-LB1820 SKC-LB1840	MYCS-ID120 MYCS-ID80 MYCS-80
8	MYBT-NR Nut Runner Series	MYBT-NR0205F	2~5	2~4	HI : 1200 LO : 800	SKC-LB1820B	MYCS-ID80-D
		MYBT-NR2507	2.5~7	2.5~5.6	HI : 850 LO : 550	SKC-LB1820B	MYCS-ID80-D
		MYBT-NR0612	6~12	6~9.6	HI : 550 LO : 350	SKC-LB1820B	MYCS-ID80-D
		MYBT-NR0815	8~15	8~12	HI : 350 LO : 220	SKC-LB1820B	MYCS-ID80-D
		MYBT-NR0308F	3~8	3~6.4	HI : 1200 LO : 800	SKC-LB1820C	MYCS-ID80-D
		MYBT-NR0515F	8~15	8~12	HI : 850 LO : 550	SKC-LB1820C	MYCS-ID80-D
		MYBT-NR1230	12~30	12~24	HI : 420 LO : 270	SKC-LB1820C	MYCS-ID80-D
		MYBT-NR1545	15~45	15~36	HI : 200 LO : 130	SKC-LB1840	MYCS-ID120 MYCS-ID80 MYCS-80
MYBT-NR2560	25~60	25~48	HI : 200 LO : 130	SKC-LB1840	MYCS-ID120 MYCS-ID80 MYCS-80		

Content



Page	Series	Model	Torque(N.m)		Free Speed (r.p.m)±10%	Applicable Battery	Applicable Charger
			Hard Joint	Soft Joint			
9~10	MYBT-AS In-Line Series	MYBT-AS0320	0.3~2.0	0.3~1.6	HI : 1200 LO : 850	SKC-LB1030S	MYCS-ID50
		MYBT-AS0830	0.8~3.0	0.8~2.4	HI : 1200 LO : 850	SKC-LB1030S	MYCS-ID50
		MYBT-AS1545	1.5~4.5	1.5~3.6	HI : 700 LO : 500	SKC-LB1030S	MYCS-ID50
		MYBT-ASP0520	0.5~2	0.5~1.6	HI : 1200 -	SKC-LB1030S	MYCS-ID50
		MYBT-ASP1030	1~3	1~2.4	HI : 1200 -	SKC-LB1030S	MYCS-ID50
		MYBT-ASP2045	2~4.5	2~3.6	HI : 700 -	SKC-LB1030S	MYCS-ID50
		MYBT-AS0105	0.1~0.5	0.1~0.4	HI : 1000 LO : 700	SKC-LB0730S	MYCS-ID25
		MYBT-AS0212	0.2~1.2	0.2~0.96	HI : 1000 LO : 700	SKC-LB0730S	MYCS-ID25
		MYBT-AS0212S1	0.2~1.2	0.2~0.96	HI : 500 LO : 350	SKC-LB0730S	MYCS-ID25

Page	Series	Model	Free Speed (r.p.m) ±10%	Torque (N.m)	Impact modes			Applicable Battery	Applicable Charger
					HI	MID	LO		
11	MYBT-IM Impact Series	MYBT-IM200	0~2100	0~200	0~200	0~160	0~120	SKC-LB1840 SKC-LB1820	MYCS-ID120 MYCS-ID80 MYCS-80
		MYBT-IM160	0~2100	0~160	0~160	0~120	0~80	SKC-LB1840 SKC-LB1820	MYCS-ID120 MYCS-ID80 MYCS-80

Page	Series	Model	Free Speed (r.p.m) ±10%	Torque (N.m)	Impact modes					Applicable Battery	Applicable Charger
					1	2	3	4	5		
11	MYBT-IM Impact Series	MYBT-IM100	0~2300	0~100	0~20	0~40	0~60	0~80	0~100	SKC-LB1820B	MYCS-ID80-D
		MYBT-IM50	0~2300	0~50	0~7	0~15	0~25	0~35	0~50	SKC-LB1820B	MYCS-ID80-D

Page	Series	Model	Torque (N.m)	Torque Adjustment	Free Speed (r.p.m) ±10%			Applicable Battery	Applicable Charger
					HI	MID	LO		
12	MYBT-SC Slip Clutch Series	MYBT-SC0612	6~12	23+MAX	700	500	350	SKC-LB1820 SKC-LB1840	MYCS-ID120 MYCS-ID80 MYCS-80
		MYBT-SC0408	4~8	23+MAX	1200	900	600	SKC-LB1820 SKC-LB1840	MYCS-ID120 MYCS-ID80 MYCS-80
		MYBT-SC1505	1.5~5	23+MAX	2200	1600	1100	SKC-LB1820 SKC-LB1840	MYCS-ID120 MYCS-ID80 MYCS-80

SMART PROGRAMMABLE IMPACT WRENCH + REMOTE CONTROL

MYBT-IM+ Series

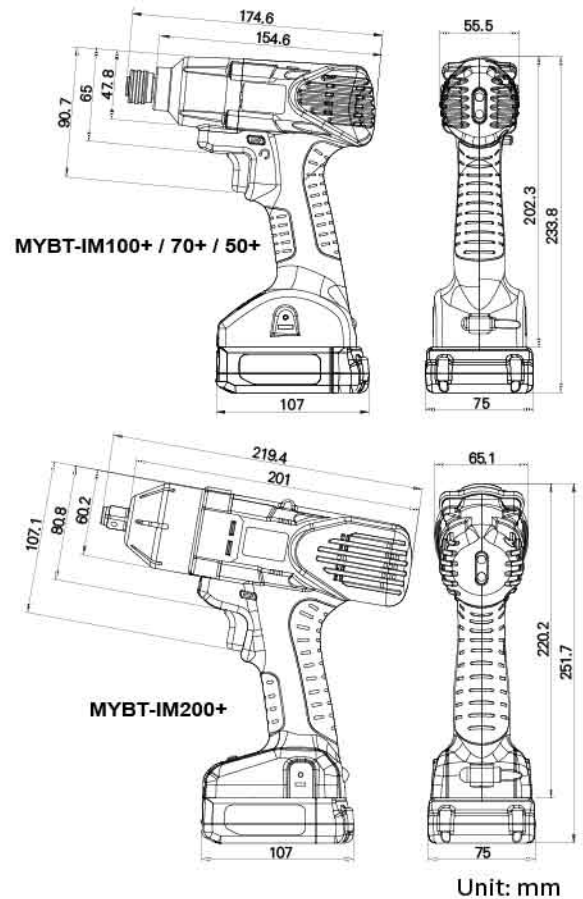

Unit: mm

Product Features

- OK & NG indicator - Prevent cross head and stripped screw to secure fastening quality.
- Program - Max. 5 programs to use in a sequence.
- Counter - Counter reminds user for no. of remaining untighten screw.
- Low battery alert - To judge best timing to change battery.
- Prohibit setting configuration - When activated, user cannot change settings without remote control. This is to avoid any user to change tool settings intentionally.
- Low voltage compensation, stable power output to ensure torque output stability.

Model No.	Output	Bolt Size	Socket Size
MYBT-IM200+	80%	M20	30mm
MYBT-IM100+	80%	M16	24mm
MYBT-IM70+	80%	M14	22mm
MYBT-IM50+	80%	M12	19mm

※ Examined by KTM-IWT400, MYBT-IM+ series torque accuracy is ±8~10%

※ Socket weight, driver handling, bolt property class, bolt size may all affect torque output.

Specifications

Model	Input Voltage	Free Speed (r.p.m)	B.P.M	Torque (N.m)	Bolt Size (Class 12.9) & Torque	Bit Type	Tool Weight (kg)	Applicable Battery	Applicable Charge Station	Torque Tester
MYBT-IM200+	14.4V	0~1700	0 ~ 2100	25 ~ 180 (Max 200)	(M12) 15 - 110 N.m (M14) 22 - 120 N.m (M16) 22 - 140 N.m (M20) 23 - 200 N.m	W 1/2"	1.5	SKC-LB1430	MYCS-ID70+	KTM-IWT400
MYBT-IM100+	14.4V	0~2000	0 ~ 2600	20 ~ 100	(M10) 8 - 40 N.m (M12) 20 - 70 N.m (M14) 20 - 90 N.m (M16) 25 - 100 N.m	B 9.5 W 3/8" W 1/2"	1	SKC-LB1430	MYCS-ID70+	KTM-IWT400
MYBT-IM70+	14.4V	0~2600	0 ~ 3400	20 ~ 70	(M8) 8 - 30 N.m (M10) 8 - 40 N.m (M12) 20 - 60 N.m (M14) 25 - 70 N.m	B 9.5 W 3/8"	1	SKC-LB1430	MYCS-ID70+	KTM-IWT400
MYBT-IM50+	14.4V	0~1900	0 ~ 2500	8 ~ 50	(M6) 3 - 20 N.m (M8) 3 - 20 N.m (M10) 5 - 30 N.m (M12) 12 - 50 N.m	B 9.5 W 3/8"	1	SKC-LB1430	MYCS-ID70+	KTM-IWT50 KTM-IWT400

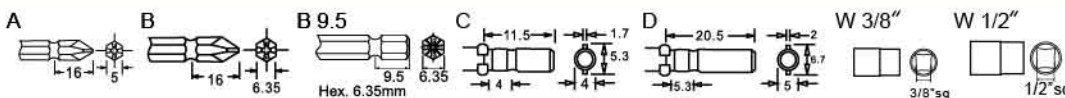

※ Tool Weight & Size indications without battery.

MYBT-EP Series



External Dimension

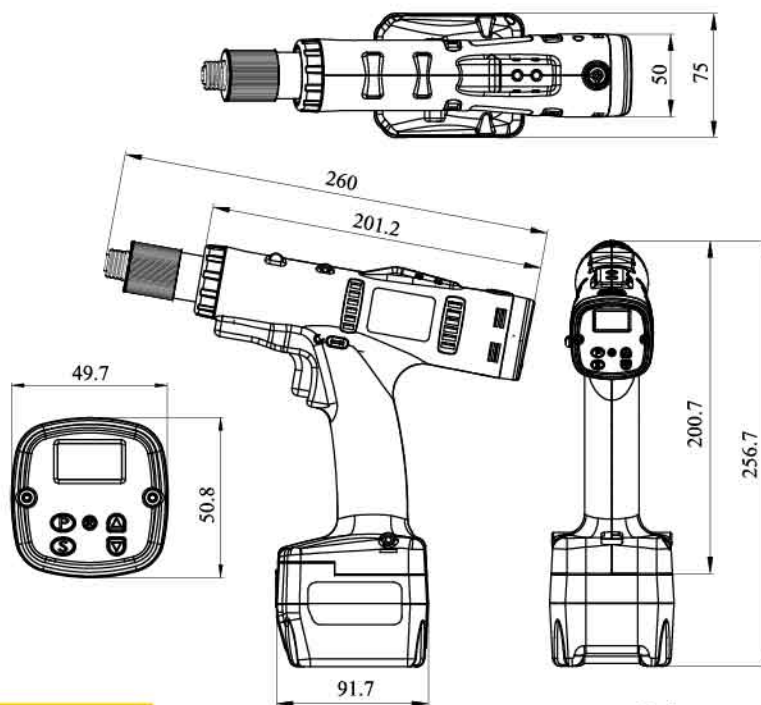

Unit: mm

Product Features

- LED illumination to light up dark areas
- Status LED to indicate users tightening results
- 10x lifespan long-lasting contactless micro switch trigger
- Built-in error-proof function to avoid costly human errors
- The durable auto shut off clutch guarantee 2 million tightening
- Smart in-process control to lock the screwdriver when an error occurred
- The sophisticated auto shut off clutch provides outstanding $\pm 3\%$ torque accuracy
- Adopted maintenance-free brushless motor for clean, quiet, and accurate operation
- A fully charged 18V lithium-ion battery can tighten up to 1,500 screws
- Auto cut off when low battery to avoid insufficient torque applied to screws
- 40 minutes quick charge

Torque Range Reference Chart

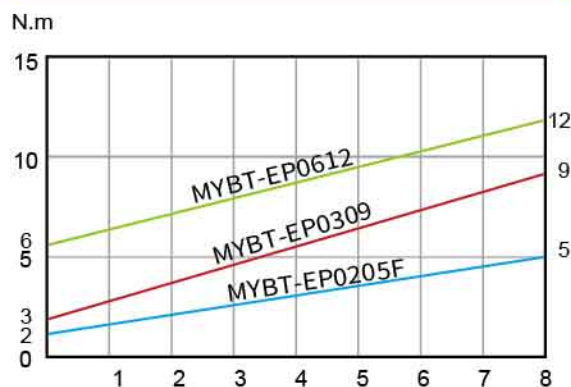

Specifications

Model	Input Voltage	Torque(N.m)		Repeatable Torque Accuracy(%)	Free Speed (r.p.m.) $\pm 10\%$	Weight (kg)	Size (mm)	Applicable Battery	Applicable Charger	Applicable Torque Meter	Bit Type
		Hard Joint	Soft Joint								
MYBT-EP0612	18V	6~12	6~9.6	$\pm 3\%$	260~880	1.2	260X200	SKC-LB1820B	MYCS-ID80-D	KTM-150	B、B9.5 W 3/8"
MYBT-EP0309	18V	3~9	3~7.2	$\pm 3\%$	300~1000	1.2	260X200	SKC-LB1820B	MYCS-ID80-D	KTM-150	B、B9.5 W 3/8"
MYBT-EP0205F	18V	2~5	2~4	$\pm 3\%$	660~2200	1.2	260X200	SKC-LB1820B	MYCS-ID80-D	KTM-150	B、B9.5 W 3/8"

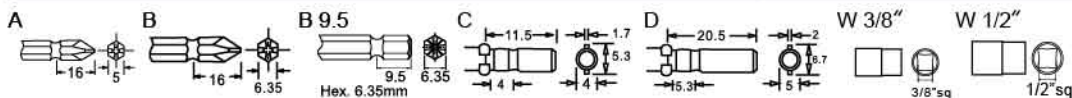

※ Free load speed will be fixed when battery volume is more than 17V (17~21V)

※ Tool Weight & Size indications without battery.

HANDY AUTOMATIC INDUSTRIAL CORDLESS SCREWDRIVER BRUSHLESS LOW TORQUE

MYBT-HD Series

External Dimension

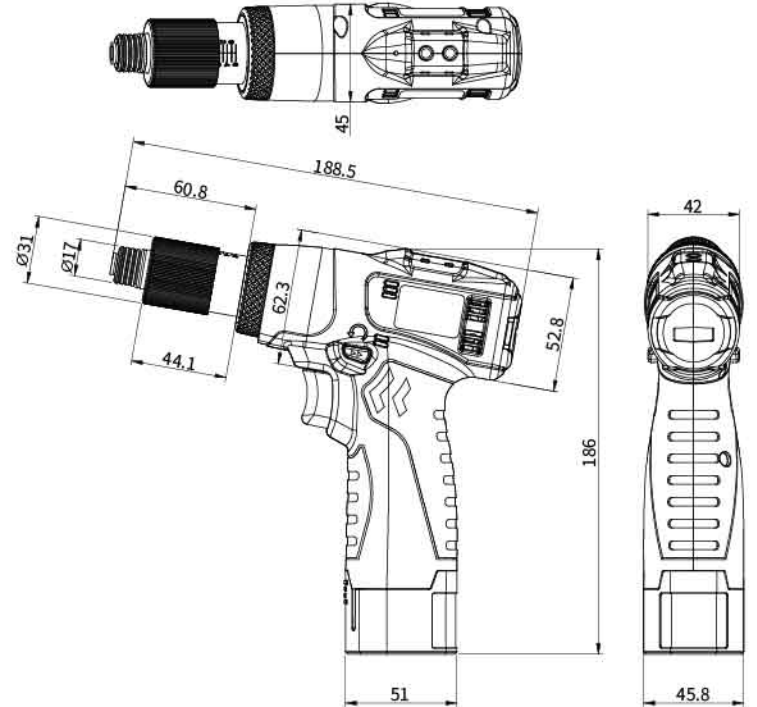

Unit: mm

Product Features

- Compact light weight ergonomic design.
- Cleaner quieter maintenance free brushless motor.
- Most ideal for areas where cables and hoses impede handling flexibility i.e. car interior electrical cabinet interiors. trains.
- 10.8V Lithium-ion battery.

Torque Range Reference Chart

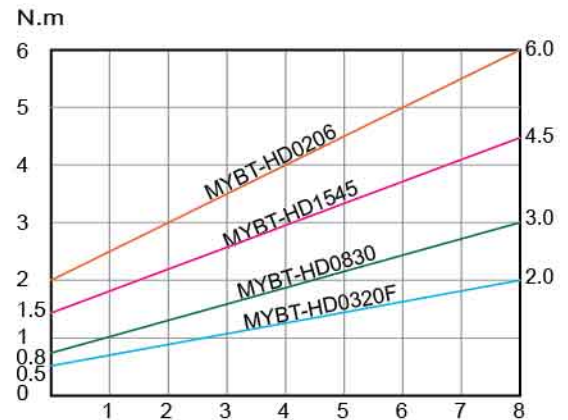

Specifications

Model	Input Voltage	Torque(N.m)		Repeatability Accuracy(%)	Free Speed (r.p.m)		Weight (kg)	Size (mm)	Applicable Battery	Applicable Charger	Bit Type
		Hard Joint	Soft Joint		HI	LO					
MYBT-HD0320F	10.8V	0.5-2.0	0.5~1.6	±3%	2700	1900	0.7	189X157	SKC-LB1030S	MYCS-ID50	A、B、B9.5
MYBT-HD0830	10.8V	0.8-3.0	0.8-2.4	±3%	1400	1000	0.7	189X157	SKC-LB1030S	MYCS-ID50	A、B、B9.5
MYBT-HD1545	10.8V	1.5-4.5	1.5-3.6	±3%	800	550	0.7	189X157	SKC-LB1030S	MYCS-ID50	A、B、B9.5
MYBT-HD0206	10.8V	2.0-6.0	2.0-4.8	±3%	650	450	0.7	189X157	SKC-LB1030S	MYCS-ID50	B、B9.5

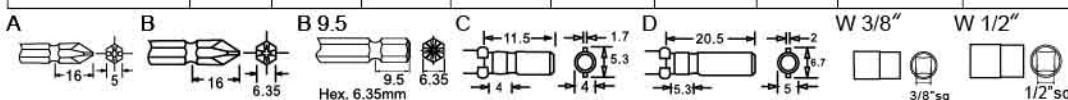

※Tool Weight & Size indications without battery.

AUTO SHUT OFF SCREWDRIVER TORQUE ADJUSTMENT EXTERNAL

MYBT-AE Series



External Dimension

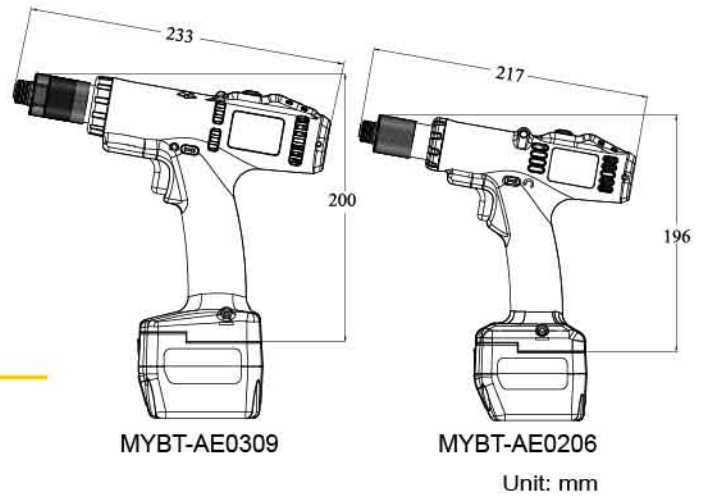

Product Features

MYBT-AE0612/MYBT-AE0309/MYBT-AE0205F

- LED illumination to light up dark areas
- Status LED to indicate users tightening results
- 10x lifespan long-lasting contactless micro switch trigger
- The durable auto shut off clutch guarantee 2 million tightening
- The sophisticated auto shut off clutch provides outstanding $\pm 3\%$ torque accuracy
- Adopted maintenance-free brushless motor for clean, quiet, and accurate operation
- A fully charged 18V lithium-ion battery can tighten up to 2,400 screws
- Auto cut off when low battery to avoid insufficient torque applied to screws
- 40 minutes quick charge

MYBT-AE0206/MYBT-AE0135/MYBT-AE0135F

- Maintenance free brushless motor with 2 years warranty
- Long lasting contactless micro switch trigger
- Precision auto shut off clutch
- Durable mechanical clutch allows 2 million tightening
- OK/NG status LED indicator
- Compact & ergonomic design
- High / Low speed selections
- LED illuminate tightening area
- Quick external torque adjustment

Torque Identification Ring



Torque Range Reference Chart

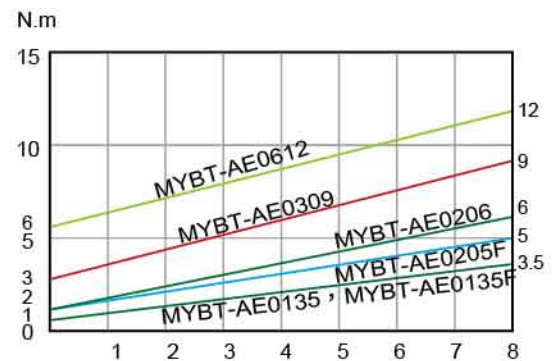

Specifications

Model	Input Voltage	Torque(N.m)		Repeatable Torque Accuracy(%)	Free Speed (r.p.m)		Weight (kg)	Size (mm)	Applicable Battery	Applicable Charger	Applicable Torque Meter	Bit Type
		Hard Joint	Soft Joint		HI	LO						
MYBT-AE0612	18V	6~12	6~9.6	$\pm 3\%$	880	570	1.1	233X200	SKC-LB1820B	MYCS-ID80-D	KTM-150	B、B9.5
MYBT-AE0309	18V	3~9	3~7.2	$\pm 3\%$	1000	650	1.1	233X200	SKC-LB1820B	MYCS-ID80-D	KTM-150	B、B9.5
MYBT-AE0205F	18V	2~5	2~4	$\pm 3\%$	2200	-	1.1	233X200	SKC-LB1820B	MYCS-ID80-D	KTM-150	B、B9.5
MYBT-AE0206	18V	2~6	2~4.8	$\pm 3\%$	1000	650	0.98	217X196	SKC-LB1820B	MYCS-ID80-D	KTM-150	B、B9.5
MYBT-AE0135	18V	1~3.5	1~2.8	$\pm 3\%$	1000	650	0.98	217X196	SKC-LB1820B	MYCS-ID80-D	KTM-150	B、B9.5
MYBT-AE0135F	18V	1~3.5	1~2.8	$\pm 3\%$	2000	-	0.98	217X196	SKC-LB1820B	MYCS-ID80-D	KTM-150	B、B9.5

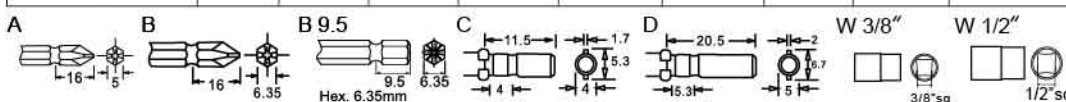

※Free load speed will be fixed when battery volume is more than 17V (17~21V)
 ※Tool Weight & Size indications without battery.

AUTO SHUT OFF SCREWDRIVER TORQUE ADJUSTMENT INTERNAL

MYBT-AI Series



Product Features

MYBT-AI0822 / MYBT-AI0615

- LED illumination to light up dark areas
- Status LED to indicate users tightening results
- 10x lifespan long-lasting contactless micro switch trigger
- The durable auto shut off clutch guarantee 2 million tightening
- The sophisticated auto shut off clutch provides outstanding $\pm 3\%$ torque accuracy
- Adopted maintenance-free brushless motor for clean, quiet, and accurate operation
- A fully charged 18V lithium-ion battery can tighten up to 2,400 screws
- Auto cut off when low battery to avoid insufficient torque applied to screws
- 40 minutes quick charge

MYBT-AI0512 / MYBT-AI0408

- Maintenance free brushless motor with 2 years warranty
- Long lasting contactless micro switch trigger
- Precision auto shut off clutch
- Durable mechanical clutch allows 2 million tightening
- OK/NG status LED indicator
- Compact & ergonomic design
- High / Low speed selections
- LED illuminate tightening area

External Dimension

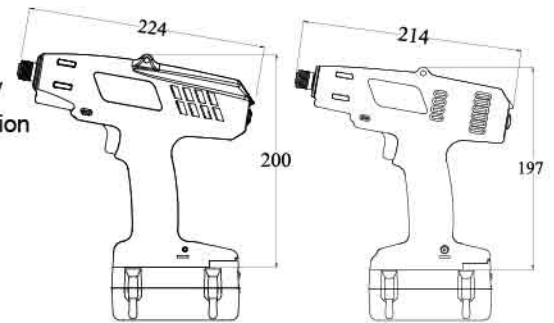

MYBT-AI0822

MYBT-AI0512

Unit: mm

Torque Identification Ring



Specifications

Model	Input Voltage	Torque(N.m)		Repeatable Torque Accuracy(%)	Free Speed (r.p.m)		Weight (kg)	Size (mm)	Applicable Battery	Applicable Charger	Applicable Torque Meter	Bit Type
		Hard Joint	Soft Joint		HI	LO						
MYBT-AI0822	18V	8~22	8~17.6	$\pm 3\%$	350	200	1.2	224X200	SKC-LB1840	MYCS-ID120 MYCS-ID80 MYCS-80	KTM-250	B · B9.5 W 3/8"
MYBT-AI0615	18V	6~15	6~12	$\pm 3\%$	600	380	1.2	224X200	SKC-LB1840	MYCS-ID120 MYCS-ID80 MYCS-80	KTM-250	B · B9.5 W 3/8"
MYBT-AI0512	18V	5~12	5~9.6	$\pm 3\%$	720	450	1.0	214X197	SKC-LB1820 SKC-LB1840	MYCS-ID120 MYCS-ID80 MYCS-80	KTM-150	B · B9.5
MYBT-AI0408	18V	4~8	4~6.4	$\pm 3\%$	1200	780	1.0	214X197	SKC-LB1820 SKC-LB1840	MYCS-ID120 MYCS-ID80 MYCS-80	KTM-150	B · B9.5

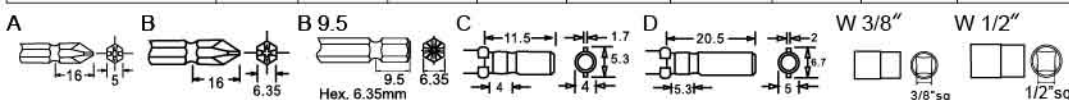

※ Free load speed will be fixed when battery volume is more than 17V (17~21V)

※ Tool Weight & Size indications without battery.

MYBT-NR Series



External Dimension

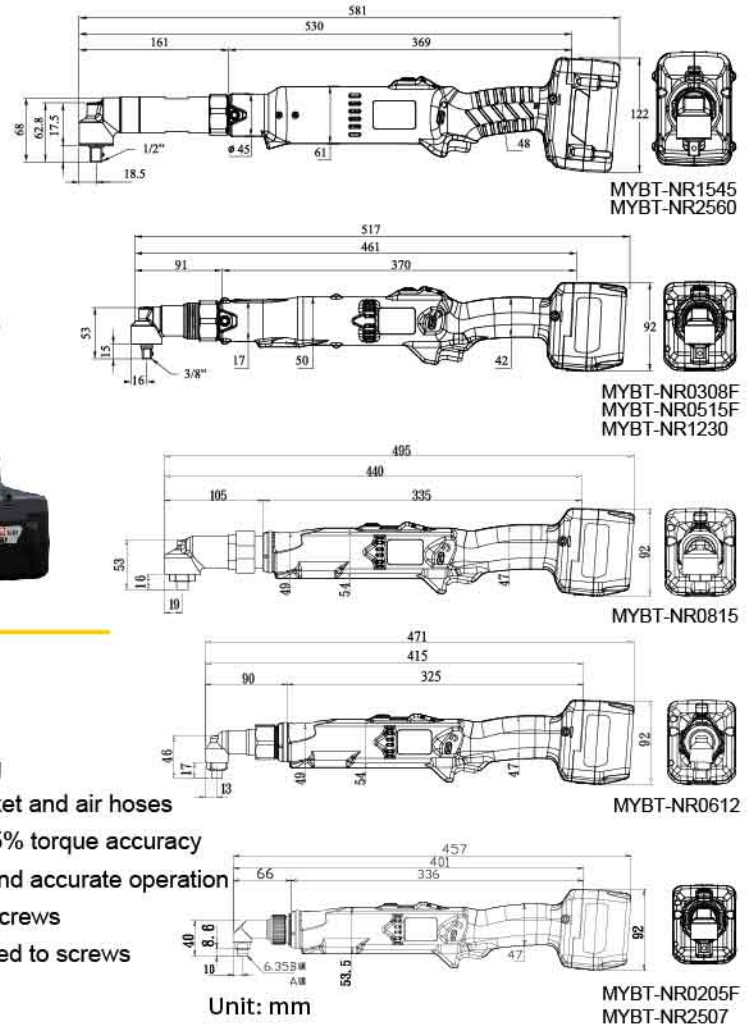

Product Features

- LED illumination to light up dark areas
- Status LED to indicate users tightening results
- 10x lifespan long-lasting contactless micro switch trigger
- The durable auto shut off clutch guarantee 1 million tightening
- Most ideal assembly tool for workstations with our power socket and air hoses
- The sophisticated auto shut off clutch provides outstanding $\pm 5\%$ torque accuracy
- Adopted maintenance-free brushless motor for clean, quiet, and accurate operation
- A fully charged 18V lithium-ion battery can tighten up to 500 screws
- Auto cut off when low battery to avoid insufficient torque applied to screws
- 40 minutes quick charge

Specifications

Model	Input Voltage	Torque(N.m)		Repeatable Torque Accuracy(%)	Free Speed (r.p.m)		Weight (kg)	Length (mm)	Applicable Battery	Applicable Charger	Applicable Torque Meter	Bit Type
		Hard Joint	Soft Joint		HI	LO						
MYBT-NR0205F	18V	2~5	2~4	$\pm 5\%$	1200	800	1.25	400	SKC-LB1820B	MYCS-ID80-D	KTM-150	B9.5
MYBT-NR2507	18V	2.5~7	2.5~5.6	$\pm 5\%$	850	550	1.25	400	SKC-LB1820B	MYCS-ID80-D	KTM-150	B9.5
MYBT-NR0612	18V	6~12	6~9.6	$\pm 5\%$	550	350	1.5	415	SKC-LB1820B	MYCS-ID80-D	KTM-150	B9.5 W 3/8"
MYBT-NR0815	18V	8~15	8~12	$\pm 5\%$	350	220	1.85	440	SKC-LB1820B	MYCS-ID80-D	KTM-250	B9.5 W 3/8"
MYBT-NR0308F	18V	3~8	3~6.4	$\pm 5\%$	1200	800	1.9	461	SKC-LB1820C	MYCS-ID80-D	KTM-150	B9.5 W 3/8"
MYBT-NR0515F	18V	8~15	8~12	$\pm 5\%$	850	550	1.9	461	SKC-LB1820C	MYCS-ID80-D	KTM-250	B9.5 W 3/8"
MYBT-NR1230	18V	12~30	12~24	$\pm 5\%$	420	270	1.9	461	SKC-LB1820C	MYCS-ID80-D	KTM-1000	W 3/8"
MYBT-NR1545	18V	15~45	15~36	$\pm 5\%$	200	130	2.85	530	SKC-LB1840	MYCS-ID120 MYCS-ID80 MYCS-80	KTM-1000	W 1/2"
MYBT-NR2560	18V	25~60	25~48	$\pm 5\%$	200	130	2.85	530	SKC-LB1840	MYCS-ID120 MYCS-ID80 MYCS-80	KTM-1000	W 1/2"

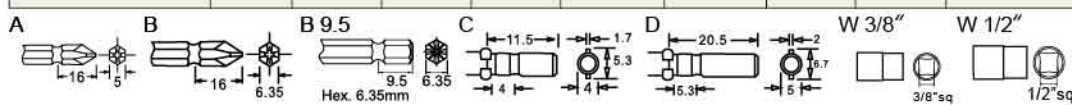

※Free load speed will be fixed when battery volume is more than 17V (17~21V)
 ※Tool Weight & Size indications without battery.

MYBT-AS Series



MYBT-ASP

MYBT-AS

Torque Range Reference Chart

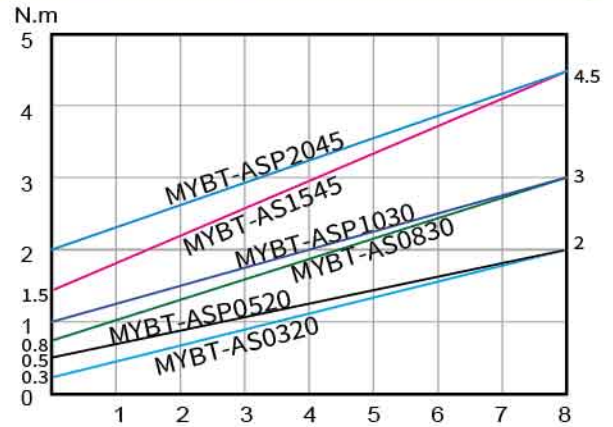

Product Features

- Unique compact and straight design (only MYBT-ASP series)
- LED illumination to light up dark areas
- Status LED to indicate users tightening results
- 10x lifespan long-lasting contactless micro switch trigger
- The durable auto shut off clutch guarantee 2 million tightening
- Unique compact straight design makes it the perfect tool for standalone station
- The sophisticated auto shut off clutch provides outstanding $\pm 3\%$ torque accuracy
- Adopted maintenance-free brushless motor for clean, quiet, and accurate operation
- A fully charged 10.8V lithium-ion battery can tighten up to 4,000 screws
- Auto cut off when low battery to avoid insufficient torque applied to screws
- 40 minutes quick charge

Accessories

90 Degree Attachment
KL-1S
(Applicable to MYBT-AS series)



External Dimension

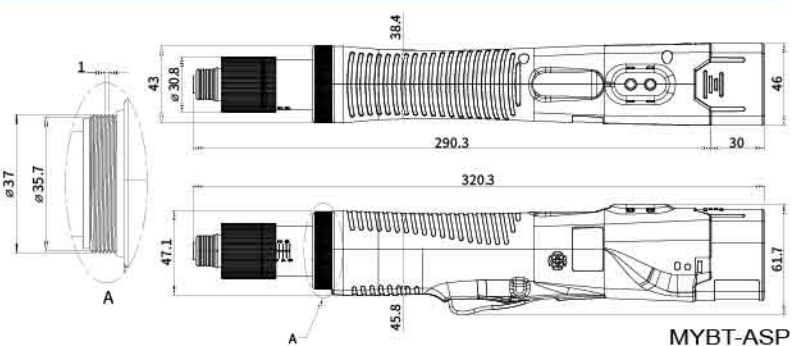
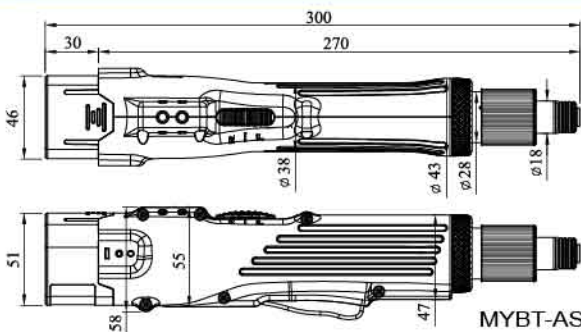

MYBT-ASP
Unit: mm

Specifications

Model	Input Voltage	Torque(N.m)		Repeatable Torque Accuracy(%)	Free Speed (r.p.m)		Weight (kg)	Size (mm)	Applicable Battery	Applicable Charger	Applicable Torque Meter	Bit Type
		Hard Joint	Soft Joint		HI	LO						
MYBT-AS0320	10.8V	0.3~2.0	0.3~1.6	$\pm 3\%$	1200	850	0.7	270X60	SKC-LB1030S	MYCS-ID50	KTM-150	A B · B9.5
MYBT-AS0830	10.8V	0.8~3.0	0.8~2.4	$\pm 3\%$	1200	850	0.7	270X60	SKC-LB1030S	MYCS-ID50	KTM-150	A B · B9.5
MYBT-AS1545	10.8V	1.5~4.5	1.5~3.6	$\pm 3\%$	700	500	0.7	270X60	SKC-LB1030S	MYCS-ID50	KTM-150	A B · B9.5
MYBT-ASP0520	10.8V	0.5-2	0.5-1.6	$\pm 3\%$	1200	-	0.72	290X62	SKC-LB1030S	MYCS-ID50	KTM-150	B9.5
MYBT-ASP1030	10.8V	1-3	1-2.4	$\pm 3\%$	1200	-	0.72	290X62	SKC-LB1030S	MYCS-ID50	KTM-150	B9.5
MYBT-ASP2045	10.8V	2-4.5	2-3.6	$\pm 3\%$	700	-	0.72	290X62	SKC-LB1030S	MYCS-ID50	KTM-150	B9.5

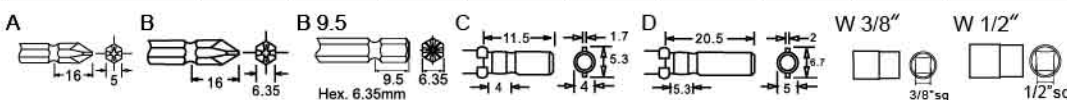

※ Tool Weight & Size indications without battery.

MYBT-AS Series

External Dimension

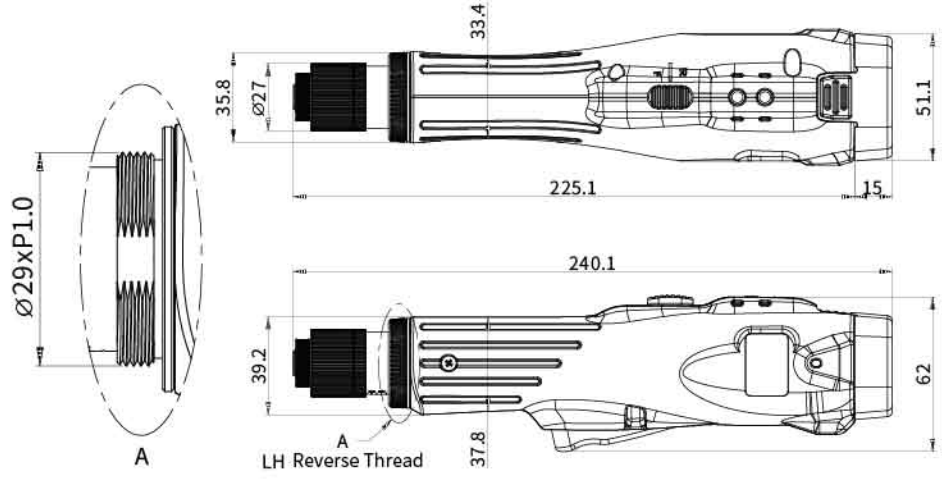

Unit: mm

Torque Range Reference Chart

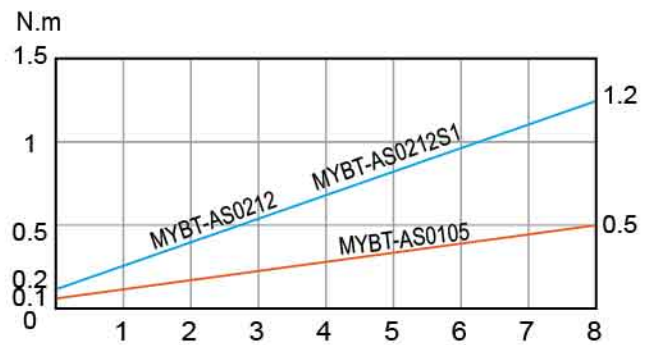

Specifications

Model	Input Voltage	Torque(N.m)		Repeatable Torque Accuracy(%)	Free Speed (r.p.m)		Weight (kg)	Size (mm)	Applicable Battery	Applicable Charger	Applicable Torque Meter	Bit Type
		Hard Joint	Soft Joint		HI	LO						
MYBT-AS0105	7.2V	0.1~0.5	0.1~0.4	±3%	1000	700	0.53	225X62	SKC-LB0730S	MYCS-ID25	KTM-15	B9.5
MYBT-AS0212	7.2V	0.2~1.2	0.2~0.96	±3%	1000	700	0.53	225X62	SKC-LB0730S	MYCS-ID25	KTM-15	B9.5
MYBT-AS0212S1	7.2V	0.2~1.2	0.2~0.96	±3%	500	350	0.53	225X62	SKC-LB0730S	MYCS-ID25	KTM-15	B9.5

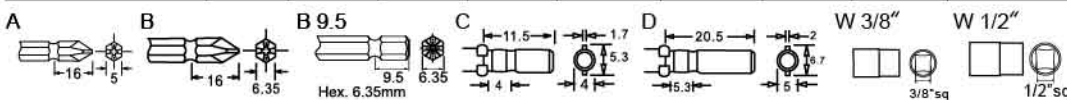

※ MYBT-AS0105 NO CE

※ Tool Weight & Size indications without battery.

MYBT-IM Series



Product Features

MYBT-IM200 · MYBT-IM160

- Maintenance free brushless motor with 1 years warranty
- Long lasting contactless micro switch trigger
- Long lifespan heavy duty hammer
- High RPM for pre tightening
- 3 auto stop torque outputs for energy saving

MYBT-IM100 · MYBT-IM50

- Maintenance free brushless motor with 1 year warranty
- Long lasting contactless micro switch trigger
- Long lifespan heavy duty hammer
- High RPM for pre tightening
- 5 auto stop torque outputs for energy saving

External Dimension

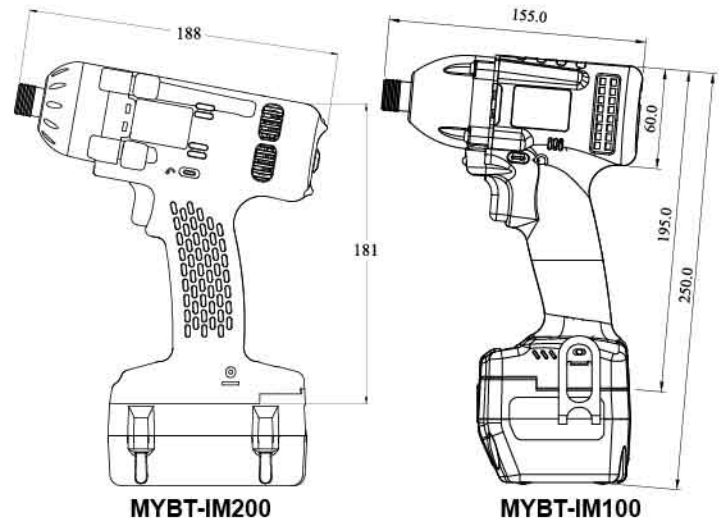

Unit: mm

Specifications

Model	Input Voltage	Free Speed (r.p.m) ±10%	B.P.M	Torque (N.m)	Impact modes					Weight (kg)	Size (mm)	Applicable Battery	Applicable Charger	Bit Type	
					HI:	MID:	LO:	1:	2:						3:
MYBT-IM200	18V	0~2100	0~3100	0~200	HI: 0~200	MID: 0~160	LO: 0~120				1.1	188X181	SKC-LB1840 SKC-LB1820	MYCS-ID120 MYCS-ID80 MYCS-80	W 1/2"
MYBT-IM160	18V	0~2100	0~2800	0~160	HI: 0~160	MID: 0~120	LO: 0~80				1.1	188X181	SKC-LB1840 SKC-LB1820	MYCS-ID120 MYCS-ID80 MYCS-80	B·B9.5 W 1/2"
MYBT-IM100	18V	0~2300	0~3000	0~100	1: 0~20	2: 0~40	3: 0~60	4: 0~80	5: 0~100		1.0	155X195	SKC-LB1820B	MYCS-ID80-D	B·B9.5
MYBT-IM50	18V	0~2300	0~3000	0~50	1: 0~7	2: 0~15	3: 0~25	4: 0~35	5: 0~50		1.0	155X195	SKC-LB1820B	MYCS-ID80-D	B·B9.5

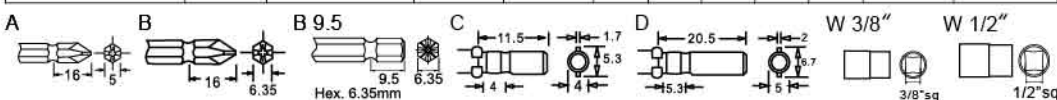

※Tool Weight & Size indications without battery.

MYBT-SC Series



External Dimension

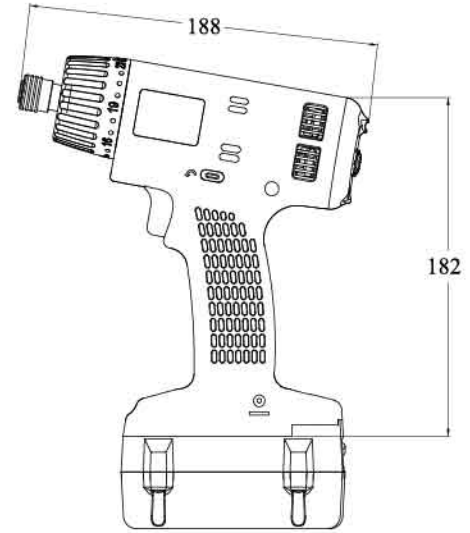

MYBT-SC0612 Unit: mm

Product Features

- Maintenance free brushless motor with 2 years warranty
- Long lasting contactless micro switch trigger
- 23 steps of slip clutch mechanical design
- High / Low speed
- Suitable for all general assembly applications

Torque Range Reference Chart

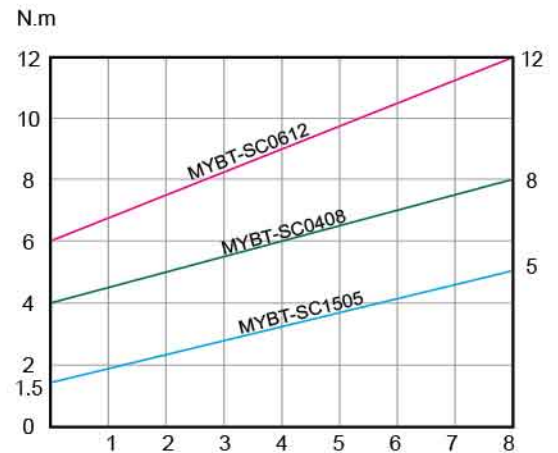

Specifications

Model	Input Voltage	Torque (N.m)	Repeatable Torque Accuracy(%)	Torque Adjustment	Free Speed (r.p.m) ±10%			Weight (kg)	Size (mm)	Applicable Battery	Applicable Charger	Bit Type
					HI	MID	LO					
MYBT-SC0612	18V	6~12	±10%	23+MAX	700	500	350	1.0	188x182	SKC-LB1820 SKC-LB1840	MYCS-ID120 MYCS-ID80 MYCS-80	B、B9.5 W 3/8"
MYBT-SC0408	18V	4~8	±10%	23+MAX	1200	900	600	1.0	188x182	SKC-LB1820 SKC-LB1840	MYCS-ID120 MYCS-ID80 MYCS-80	B、B9.5 W 3/8"
MYBT-SC1505	18V	1.5~5	±10%	23+MAX	2200	1600	1100	1.0	188x182	SKC-LB1820 SKC-LB1840	MYCS-ID120 MYCS-ID80 MYCS-80	B、B9.5 W 3/8"

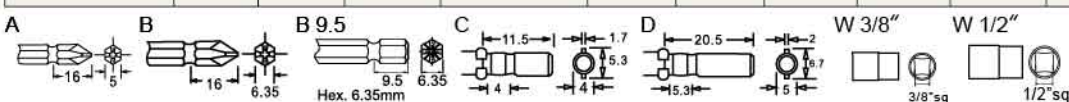

※ Tool Weight & Size indications without battery.

MYCS Series



MYCS-ID80-D



MYCS-ID80/80



MYCS-ID70+



MYCS-ID120



MYCS-ID50



MYCS-ID25

Product Features

- Built-in LCD display shows recharging status. If the temperature is over the limit when recharging, the charge station will activate the protection function to stop recharging.
- Charge station can identify whether battery is supplied by KILEWS. When other brands of batteries installed on the charge station, it will not start charging process for the safety protection.
- Charge station can detect recharging time and battery capacity automatically. If any unusual situation happens during recharging, it will give an alert beeps and warning light to warn users.
- Auto buzzer reminds when battery is fully recharged.
- Small size, light weight, quick recharge, and wide voltage range 100~240ACV can be applicable worldwide.

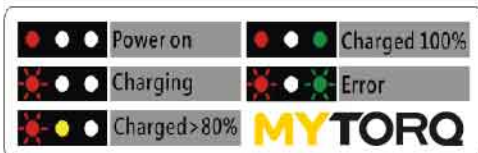
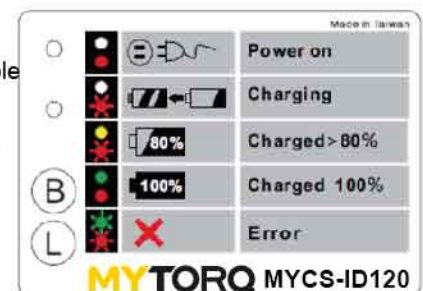

MYCS-ID80 / MYCS-80 / MYCS-ID80-D

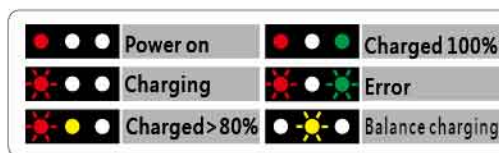

MYCS-ID70+ / MYCS-ID50 / MYCS-ID25

Specifications

Model	MYCS-ID120	MYCS-ID80	MYCS-80	MYCS-ID80-D	MYCS-ID70+	MYCS-ID50	MYCS-ID25
Input Voltage	100V~240V	100V~240V	100V~240V	100V~240V	100V~240V	100V~240V	100V~240V
Output Voltage	21V DC	21V DC	21V DC	21V DC	16.8V	12.6V	8.4V
Output Current	3.0~4.5A	3.0A	3.0A	3.0A	3.0A	3.0A	3.0A
Applicable battery model	SKC-LB1820/1840	SKC-LB1820/1840	SKC-LB1820/1840	SKC-LB1820B/C	SKC-LB1430	SKC-LB1030S	SKC-LB0730S
Battery Identification	√	√	-	√	√	√	√
Buzzer	√	√	-	√	√	√	√
Cooling fan	√	-	-	-	-	-	-
Dimensions(WXLXH)	160X170X80mm	145X115X80mm	145X115X80mm	145X115X80mm	145X115X75mm	145X115X93mm	115X145X101mm
Weight	1068g	530g	530g	530g	460g	470g	430g
LCD Display	√	-	-	-	-	-	-
Safety Certification	CE·ETL	CE·ETL	CE·ETL	CE·ETL	CE·ETL	CE·ETL	CE·ETL

MYCS-ID120 Will display battery ID, each recharging time, cell temperature, battery voltage, recharge status.

SKC-LB Series



SKC-LB1820



SKC-LB1840



SKC-LB1430

Product Features

- Adopting Japanese and Korea high performance Li-ion (Li-Mn) battery.
- Built in protection device to prevent battery overcharge and over discharge.
- The latch design increases intensity and convenience when assembling or dismantling the rechargeable battery from the cordless screwdriver.
- Fully charged voltage: 21V, low-voltage protection: 13.5V, over-temperature protection (discharge): 72°C.
- Battery ID identification design, which only allows original charge station to recharge the battery to secure battery safety and extend battery lifetime.



SKC-LB1820B



SKC-LB1030S



SKC-LB1820C



SKC-LB0730S

Battery charging time reference

Battery Model / Capacity	MYCS-ID120	MYCS-ID80	MYCS-80	MYCS-ID80-D	MYCS-ID70+	MYCS-ID50	MYCS-ID25
SKC-LB1820	40 min.	40 min.	40 min.				
SKC-LB1840	60 min.	80 min.	80 min.				
SKC-LB1820B/C				40 min.			
SKC-LB1430					70 min.		
SKC-LB1030S						55 min.	
SKC-LB0730S							70 min.

Specifications

Battery Model	SKC-LB1820	SKC-LB1840	SKC-LB1820B	SKC-LB1820C	SKC-LB1430	SKC-LB1030S	SKC-LB0730S
Voltage	18V	18V	18V	18V	14.4V	10.8V	7.2V
Capacity	1950mA/hr	3900mA/hr	2000mA/hr	2000mA/hr	3000mA/hr	3000mA/hr	3000mA/hr
Rated voltage	18V	18V	18V	18V	14.4V	10.8V	7.2V
Power	35Wh	70Wh	36Wh	36Wh	43.2Wh	32.4Wh	21.6Wh
Cells Permutation	5 series 1 parallel	5 series 2 parallel	5 series 1 parallel	5 series 1 parallel	4 series 1 parallel	3 series 1 parallel	2 series 1 parallel
Weight	430g	720g	430g	430g	327g	194g	128g
Dimensions(mm)	119X90X40	119X90X59	92X75X63	92X75X63	107X75X43	51X46X90	51X44X70
Certification	CE·ETL	CE·ETL	CE·ETL	CE·ETL	CE·TUV	CE·TUV	CE·TUV
UN38.3 Inspection report	YES	YES	YES	YES	YES	YES	YES

KTM Series

TRANSDUCER TYPE IMPACT TORQUE TESTER KTM-IWT50 / KTM-IWT400

Patented design for testing various power type tools, impact wrench, oil pulse tool and manual wrench.

- Can set peak value sampling time (0 - 99 sec.)
- Can set sampling time after peak detected
- Double displays to show peak and real time value
- Auto clear peak value
- Optional torque unit : kgf.cm , N.m, lbf.in



KTM-IWT50



KTM-IWT400

Model No.	Torque Test Range			Applicable Bolt	Bolt Class	Torque Accuracy	Size (mm)	Weight (KG)	Power	Accessory
	Kgf.cm	Lbf.in	N.m							
KTM-IWT50	0 ~ 509	0 ~ 442	0 ~ 50	M6 / M8 / M10	12.9	±10% of reading	200 x 190 x 285	12.6	Input 100 - 240 Vac	M6 & M8 & M10 joint and bolt are included in tester.
KTM-IWT400	0 ~ 4079	0 ~ 3540	0 ~ 400	M10 / M12 / M14 / M16	12.9	±10% of reading	295 x 200 x 305	29.7	Input 100 - 240 Vac	M10 & M12 & M14 & M16 joint and bolt are included in tester.

KTM-1000 / 250 / 150 / 15 / 6 / 50S

- LED can identify the test range of torque setting by needed user. If the result is not complying to torque range setting, light will be warned.
- USB connector is only used for data output, it is convenient for user to work with computer.
- Auto-zero can be selected and zero reset becomes unnecessary for user.
- Automatically test values about maximum, minimum and mean.
- ✳KTM-6, KTM-15, KTM-150, KTM-250, KTM-1000 are suitable for shut off type screwdriver only.
- ✳KTM-50S is for semi-shut off type electric screwdriver only.



KTM-1000



KTM-250



KTM-6 / 15 / 150



KTM-50S

Model	KTM-1000	KTM-250	KTM-150	KTM-15	KTM-6	KTM-50S	
Measuring Ranges	(kgf.cm)	50~1000	3.0~250.0	1.5~150.0	0.15~15.0	0.02~8.0	0.5~50.0
	(Lbf.in)	45~885	3.0~217.0	1.5~130.0	0.15~13.0	0.02~7.0	0.5~43.4
	(N.m)	5~100	0.30~25.00	0.15~15.0	0.015~1.500	0.002~0.8	0.05~4.90
Accuracy	+/- 0.5%(20~100N.m) +/- 1.0%(10~20N.m) +/- 2.0%(5~10N.m)		+/- 0.5%				
Power Supply	3.7V, 4400mAh Lithium Ion		4.8VDC (Ni-MH chargeable battery 1.2VX4 cell 1650mAh)				
Charging Time	8 hours		From empty -3 hours				
Operation Time	8 hours		About 12 hours				
Battery Life	Chargeable for 300 times or more. However, it varies depending on operating conditions.						
Size(mm)	229(W)X102(D)X80(H)	160(W)X210(D)X45(H)	230(W)X125(D)X65(H)			230(W)X123(D)X65(H)	
Weight(kg)	2.7	2.0	1.8		1.8	1.8	
Exclusive Charger	Input : AC100V~240V 50/60Hz Output : DC5V 1.0A Max		Input : AC100V~240V 50/60Hz Output : DC12V 400mA				
Accessory	Torque measuring adaptorX1 SJ-1000	Torque measuring adaptorX1 AJ-250	Torque measuring adaptorX3 AJ-150 / AJ-50 / AJ-15K	Torque measuring adaptorX2 AJ-15 / AJ-3	Torque measuring adaptorX1 AJ-3	Torque measuring adaptorX1 AJ-50S	

KP-AUX Series / ACCESSORIES

Auxiliary Arm

Model No.	Max torque (Nm)	A(mini/maxi) cm	diameter(mm) Tool Ø
KP-AUX-C50-1000	50	43~100	38.5~52
KP-AUX-E50-1000			
KP-AUX-B50-1000			
KP-AUX-D50-1000			
KP-AUX-C50-1200	50	50~120	38.5~52
KP-AUX-E50-1200			
KP-AUX-B50-1200			
KP-AUX-D50-1200			

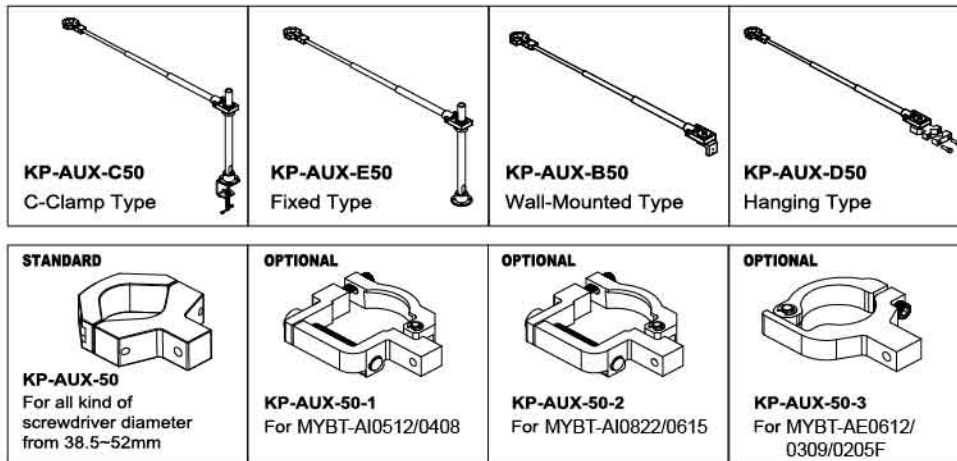
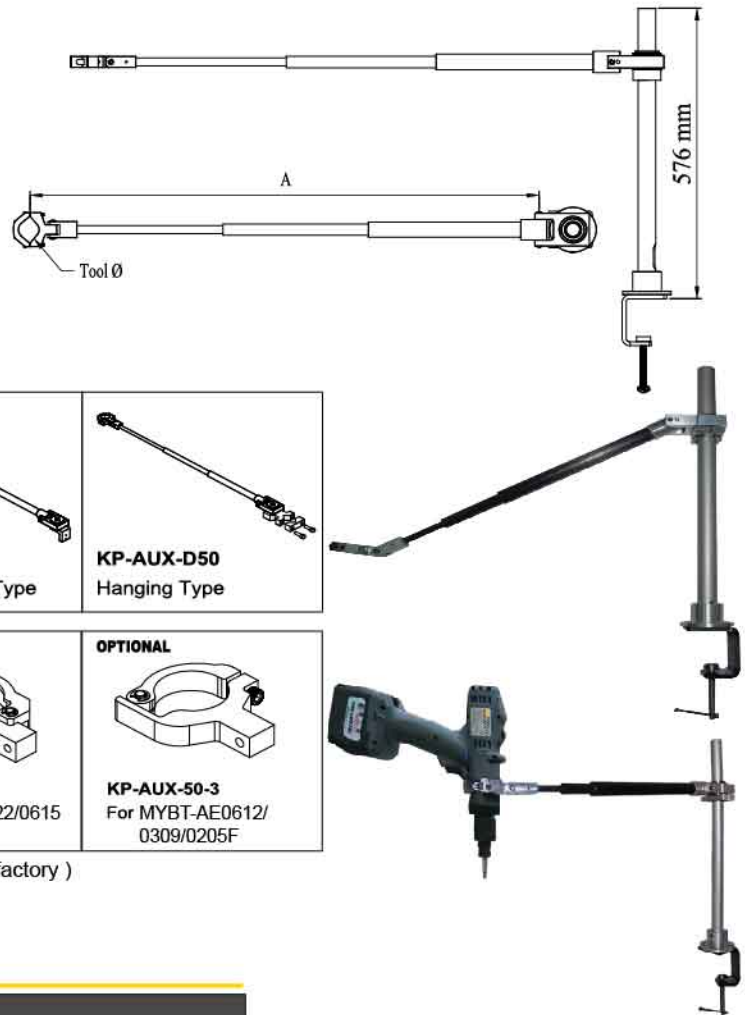

MYTORQ product is made by SAING EI CORP. (Kilews subsidiary factory)

Screwdriver Holder

Model	Applicable Models
KH-1	MYBT-AS0320(&KC) / MYBT-AS0830(&KC) / MYBT-AS1545(&KC)
KH-2	MYBT-AS0320 / MYBT-AS0830 / MYBT-AS1545
KH-5	MYBT-AS0212 series
KH-6	MYBT-EP0612 / MYBT-EP0309 / MYBT-EP0205F MYBT-AE0612 / MYBT-AE0309 / MYBT-AE0205F MYBT-AE0206 / MYBT-AE0135 / MYBT-AE0135F MYBT-AI0512 / MYBT-AI0408
KH-7	MYBT-AI0822 / MYBT-AI0615
KH-1L	MYBT-ASP(&KC)
KH-2L	MYBT-ASP

- The new screwdriver holder series can be fixed on the table or wall.
Position angle of the rack can be adjusted for operator easier to pick up and restore the screwdriver.



Torque Locker

Model	Applicable Models
KC-28A	MYBT-AS0320 MYBT-AS0830 MYBT-AS1545



SmartCost
Partnership : Solution

บริษัท สมาร์ทคอสท์ จำกัด

๑ 41 ซอยเฉลิมพระเกียรติ ร. 9
ซอย 14 แยก 22 แขวง หนองบอน
เขต ประเวศ กรุงเทพฯ 10250

☎ 02-747-3636

✉ info@smartcost.co.th

🌐 <https://smartcost.co.th>



YT99938-2